

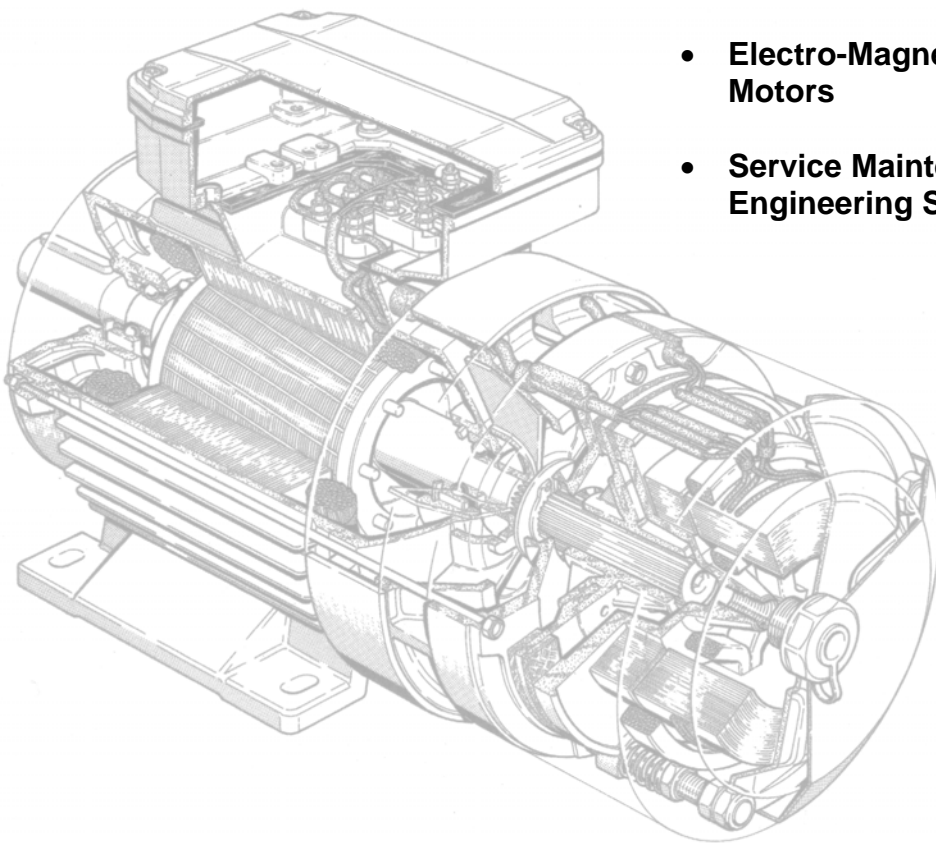

Products and Services

- Low Voltage AC Motors
- High Voltage Motors
- Direct Current Motors
- Geared Motors and Speed Reducers
- Transformers
- Variable Speed Drives
- Industrial Pumping Equipment
- Electro-Magnetic Brakes and Brake Motors
- Service Maintenance and Engineering Solutions.



Service, Maintenance and Engineering Solutions



✓ Complete Rewind, Repair, Redesign and Mechanical Modification Services to new or existing A.C. and D.C. electric motors.



✓ Rewinding of Transformers, Brakes, Coils, Alternators and Generators.

✓ Repair and Mechanical Overhaul Services to Industrial Gearbox's and Speed Reducers.



✓ Dynamic Balancing of all Rotating Equipment.

✓ Vibration Analysis and Laser Alignment.

✓ Machining and Fabrication of Special Shafts or Mounting Arrangements.



✓ Preventative Maintenance Programs and On-Site Services.

✓ Refurbishing of Industrial, Commercial and Domestic Pumps and Pumping Equipment.



Dedicated Service, Workshop Packages & Customer Support Engineers

EMT can solve your Engineering & Machining problems!

- ✓ General Engineering & Machining.
- ✓ Reproduction of Worn or Damaged Components.
- ✓ MIG Welding & Fabrication of Bases and Skids for Pumps and Gear Heads.
- ✓ Manufacturing Jigs, Fixtures & Press Tools.
- ✓ Design, Engineering and Fabrication of all types of Special Purpose Machinery.



Everything it takes to repair, rebuild and customise large electrical and mechanical machinery !

Emt **Totally Enclosed – Single Phase Motors.**

IP55 protection, Aluminium multi-mount construction.
 Capacitor Run for fan & pump drive application or Capacitor Start/Capacitor Run for high starting torque applications. Ratings from 0.09KW up to 4KW in IEC frames 56 to 112. Available in Foot, Flange or Face mountings.



Emt **Totally Enclosed - e-Drive Series, Energy Saving Three Phase Motors. EFF1 and MEPS 2006 Compliance:**

IP55 protection, Multi-Voltage / Multi-Frequency ratings.
 Aluminium multi-mount construction from 0.09KW to 7.5KW in IEC frames 56 to 132.
 Cast Iron construction from 0.37KW to 1000KW in IEC frames 71 to 560
 Available in Foot, Flange or Face mountings.



EFF I MEPS Compliant

Emt **Open Drip-Proof – Energy Efficient Three Phase Motors.**

IP23 protection, Cast Iron construction with ratings from 185KW to 710KW in IEC frames 315 to 355. Available in Foot and/or Flange mountings.



Emt **Fail Safe Brakes and Brake Motors - Single Phase or Three Phase**

Totally Enclosed Brake motors with single speed or multi speed ratings complete with fast-acting AC or DC brake coils and braking torques to suit all load types.
 Available in Foot, Flange or Face mountings.
 EMB-LS Electro magnetic disc brakes from 4Nm to 360Nm.



Emt **Hazardous Location Three Phase Motors.**

Exd, Exe, Exn or Dust Ignition-Proof enclosures complying with Australian and International Standards. Available in Foot, Flange or Face mountings.



Emt **Right Angle, Helical In-Line and Mechanical Variator Geared Motors**

Available in both AC and DC motor configurations with multi-mount aluminium or cast iron construction. Hollow shaft or solid shaft outputs.



Emt **High Voltage Motors.**

Cast Iron and Fabricated Steel Frames
 Totally Enclosed and Open Drip Proof enclosures with degree of protection from IP23 to IP56.
 Squirrel Cage and Slip Ring (Wound Rotor) types.
 Voltage ratings from 3KV to 11KV with
 Outputs from 185KW to 5000KW in IEC frames 355 to 1000
 Available in Foot and/or Flange mountings on short lead times



EMT Products

Direct Current Motors

Whether it be a small Low Voltage, Permanent Magnet motor or a Large Wound Field motor, EMT can provide the best solution for DC Motors and DC Speed Controllers.

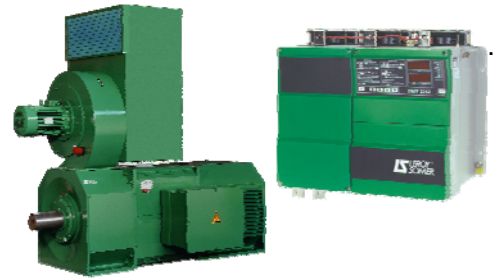

Variable Speed Drives

We offer an extensive range of AC Variable Frequency Drives covering both Single phase and 3 phase ratings from 0.12KW to 4300KW. Advanced technology and features along with worldwide support.



Inverter Drive Motors and Constant Velocity Cooling Units.

Achieve continuous cooling of AC motors used on Inverter, DTC and Flux Vector Drives, regardless of the motor shaft speed. EMT can supply an extensive range of motors suitable for Inverter Drive applications along with EMT Constant Velocity Fan units to suit all sizes and makes of industrial motors



Pumps and Pumping Equipment

EMT is an Authorised Sales and Service Agent for many types and brands of Industrial, Commercial and Domestic Pumps and Pumping Equipment, including ONGA and LOWARA



Special Purpose Machinery & Fabrications.

Designed, Manufactured and Guaranteed to suit our customers specific requirements.



Combined Pump Skid
& Diesel Fuel Tank



Transformer Oil
Transfer Pump



Centrifugal
Pump Sets



Variable Speed
Geared Motor with Remote Control

EMT Pty Limited

EMT Head Office & NSW Sales:

1 / 114 Station Rd, Seven Hills. NSW, Australia 2147
Phone: (02) 9838 8181 Fax: (02) 9838 8421

EMT Monophase:

40 Sydenham Rd, Brookvale NSW 2100
Phone: (02) 9905 2755 Fax: (02) 9905 7399

EMT Victorian Sales:

Phone (03) 9796 0355 Fax: (03) 9796 0377

Email: sales@emtmotor.com.au

Internet: www.emtmotor.com.au



Or call from anywhere within Australia for local call cost - Ph: 1300 13 9181